

Enable 3D View

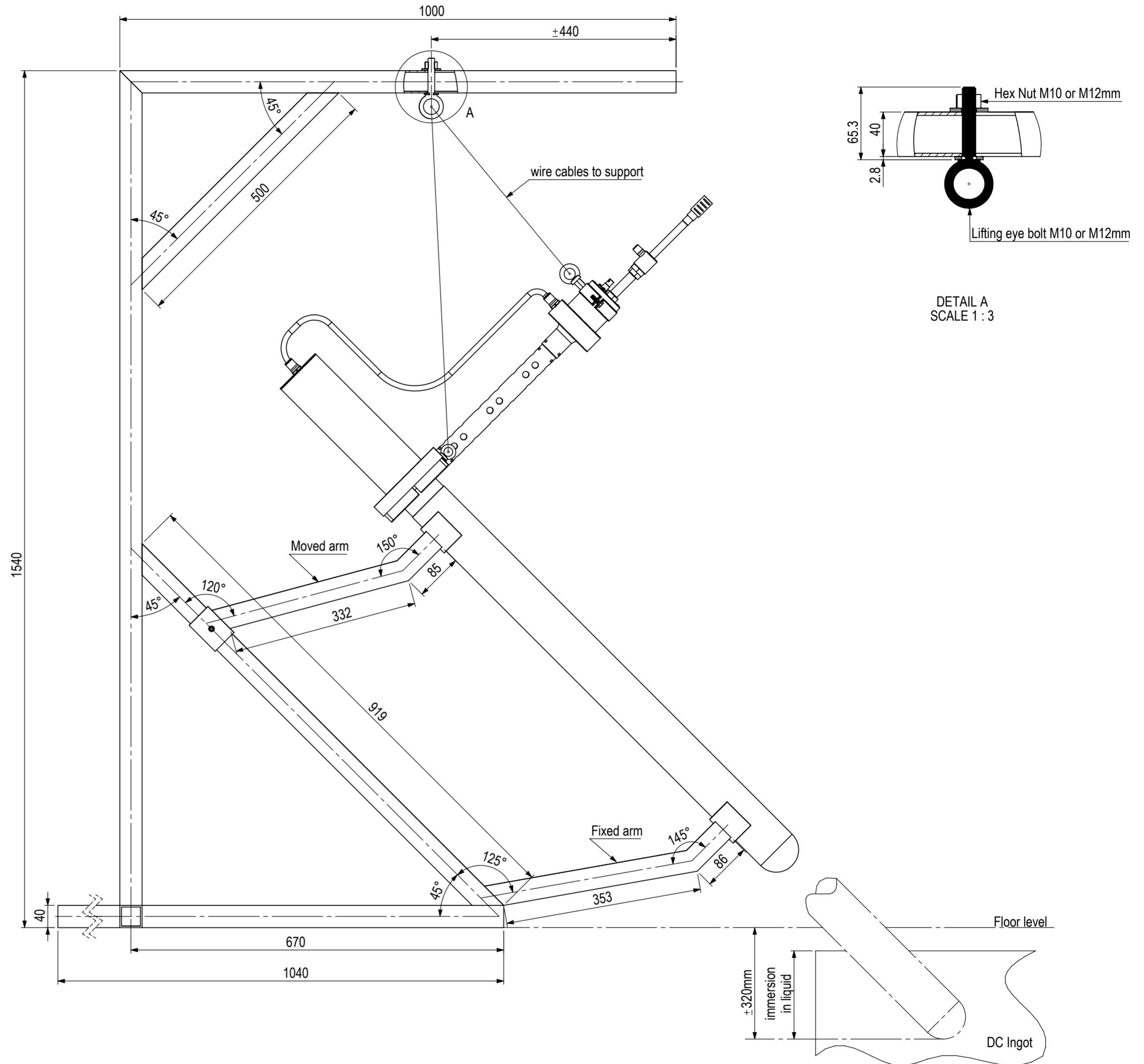
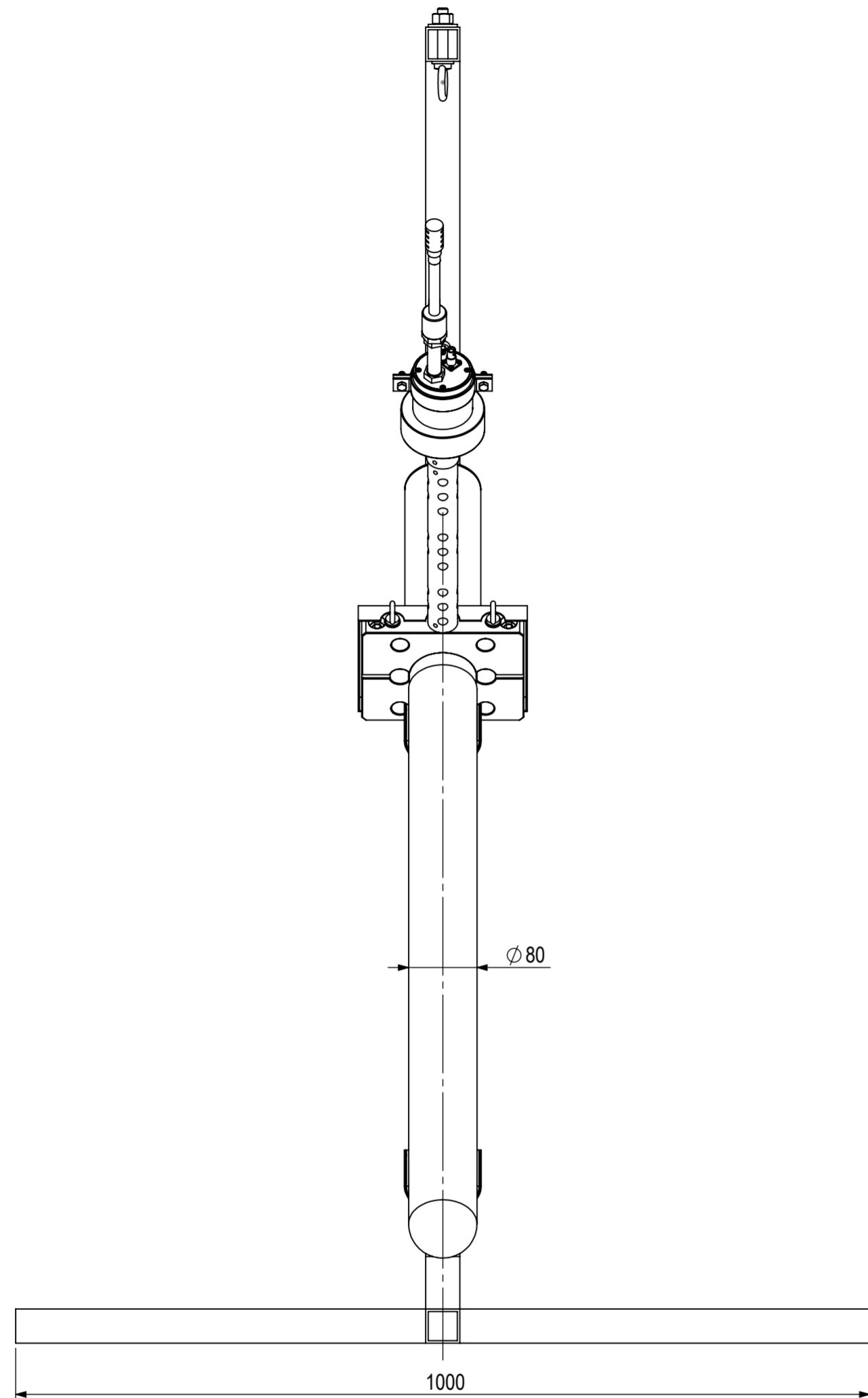

Note:

All dimensions will be dependent of support table of DC casting machine. Profilglass should measure and adjust to real conditions.

All square tubes should be welded.

PROJECT DIRECTOR M.Prokic	DATE 07.05.2014	DEBUR AND BREAK SHARP EDGES	DO NOT SCALE DRAWING	REVISION		
drew H. Puga	DATE MODIFY		MPI-ULTRASONICS MARAI 36 2400 Le Locle Switzerland e-mail : mpi@mpi-ultrasonics.com phone +41 (0) 32 9314045			
MATERIAL:						
General tolerance SN 258440						
dimension nomiale (mm)	>3 ...6	>6 ...30	>30 ...120	>120 ...400	>400 ...1000	>1000 ...2000
Ecart (mm)	± 0.05	± 0.1	± 0.15	± 0.2	± 0.3	± 0.5
			Guiding Holding Frame		SCALE: 1:5	SHEET 1 OF 1